

# X1000

Robot Vacuum Cleaner

## User Manual

**EN** English

**DE** Deutsch

**FR** Français

**ES** Español

**IT** Italiano

**PL** Polski

**DK** Dansk

**FI** Suomi

**NO** Norsk

**SE** Svenska

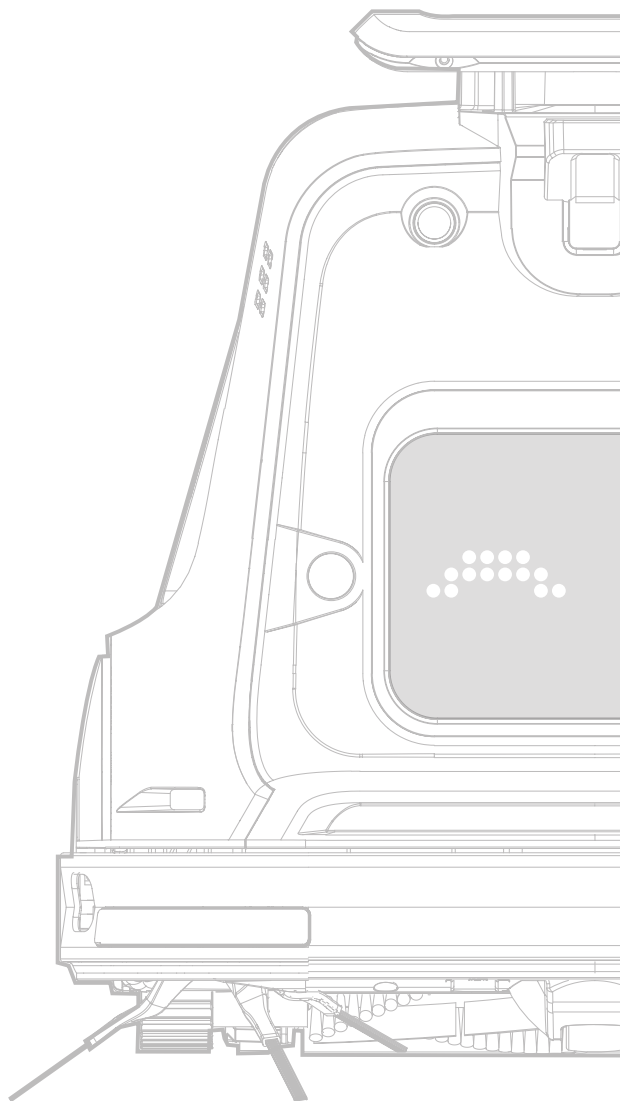

Find more information at [www.zaco-pro.eu](http://www.zaco-pro.eu) | ZACO

## Dear Customer,

thank you for purchasing the **ZACO X1000** robot vacuum cleaner! You've joined the millions of people who clean with robots – the smarter way to get it done. Please take a few moments to read this manual and get acquainted with your robot, to get the best performance from your robot.

If you have any problems, don't worry, contact our customer service or visit our website at **www.zaco-pro.eu** for more information.

Best regards,  
**ZACO Customer Service**

## ZACO Customer Service

### Customer Service Number

00800-42377961 (European Free Call)

0209-513038-38 (Direct Line – DE)

support@zaco.eu | www.zaco-pro.eu

### Robovox Distributions GmbH

Hamburger Straße 11 | 45889 Gelsenkirchen | Germany

### Social Media



RobovoxZACO



zaco\_robot



ZACO Robot

# Contents

<b>Safety Instructions</b>	4
Safety	4
Product	5
Maintenance	7
Disposal	7
<b>Product parts</b>	8
List of Accessories	8
Main product	9
Charging station	10
Dust bin, Filter and Battery	11
<b>Product operation</b>	12
Preparation Before Operating	12
Installing the Battery	12
Charging Station	13
Charging   Auto Charge	14
Start	14
Pause	15
Cleaning Mode Selection	15
<b>Product Settings</b>	16
<b>App download and operation instruction</b>	19
App Download	19
Connect the App	19
Disconnect the App	23
Control Robot	23
<b>Maintenance</b>	24
<b>Product Specifications</b>	29
<b>Protection Class</b>	30
<b>ErP Information</b>	31
<b>Frequency Band</b>	32
<b>EU Declaration of Conformity</b>	32

## Safety instructions

---



### WARNING

Before using the electrical device, basic precautions should always be followed. Read all instructions before using this appliance. Please save these instructions.

### Use instructions | Safety

- 1** This device is not suitable to be used by children under 8 years old and people with physical or mental disabilities. If used by children, operate the device under the supervision of the guardian. Don't let the child sit on the robot. The robot is not a toy.
- 2** Please remove obstacles before using the robot. Such as power cords and other items. Please fold the edge of the carpet under the carpet. Do not let the curtain and tablecloth touch the floor.
- 3** If there are drops like stairs, please test if the robot can detect the edge without falling.
- 4** Please follow the instructions to operate the robot.
- 5** Make sure the power supply voltage matches the voltage marked on the charging base.
- 6** Indoor use only. Do not use outdoors.
- 7** Only use the original rechargeable battery and charging base provided by the manufacturer. Non-rechargeable batteries are strictly forbidden to use. Battery specifications please refer to the technical parameters.

# Safety instructions

---

## Use instructions | Product

- 8** Do not clean the robot with water.
- 9** Do not wipe the robot with wet cloth.
- 10** Do not use on wet floor.
- 11** Do not use in open fire and fragile environment.
- 12** Do not let clothes, hair and fingers come close to the product's openings or operating parts.
- 13** Do not let the robot suck any material that might block the suction pipe, such as stones, waste, paper, etc.
- 14** Do not let the robot absorb any flammable materials, such as gasoline and toner from a printer or photocopier.
- 15** Do not let the product to absorb any products that are burning, such as cigarettes, matches, ashes, and other products that may cause a fire.
- 16** Do not block the product on the suction vent. Do not use the robot if suction vent is blocked. Clean up dust, hair, cotton, etc., to ensure the air at the sucking mouth flows smoothly.
- 17** Do not use the charging base if it is damaged.
- 18** Use the power cord carefully to avoid damage. Do not use the power cord to drag and pull the product or its charging base. Do not let the product run on the power cord and keep the power cord away from heat.

# Safety instructions

---

## Use instructions | Product

- 19** If the power cord is damaged; it must be replaced by qualified maintenance staff.
- 20** Make sure the dust bin and filter are properly installed before using.
- 21** Do not use the robot in an infant sleeping room.
- 22** Do not use the robot when the product is damaged due to drop, water, or outdoor use. And please let the robot be repaired by the manufacturer and its service department.
- 23** If the Product is not being used for a long period of time disconnect it from the power supply.

# Safety instructions

---

## Use instructions | Maintenance

- 24** Before cleaning and maintaining the product, please turn off the power switch first.
  - 25** Before cleaning and maintaining the product, please pull the power cord out of power socket.
- 

## Use instructions | Disposal

- 26** Before disposing of the product, please remove the product from the charging base, turn the power switch off and remove the battery.
- 27** Before disposing of batteries, you must follow local laws and regulations.
- 28** Even if the product is severely damaged, it is forbidden to incinerate the product and the battery. This may cause an explosion.
- 29** Please follow the instructions to use the product. Due to improper use of any loss and damage, the company will not take any responsibility.

## Product parts

### List of Accessories



X1000 (with two batteries)

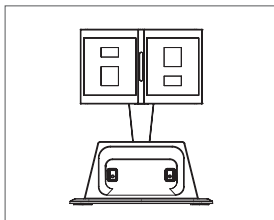

Charging station

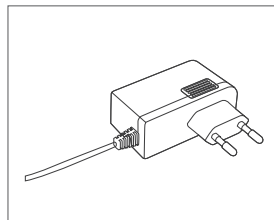

Charging cable

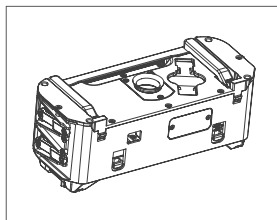

Suction Port Modules

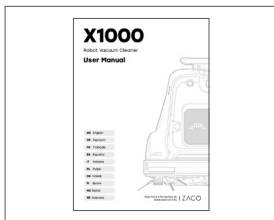

User Manual

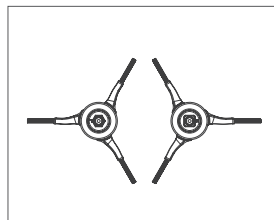

2x Left and Right Brush

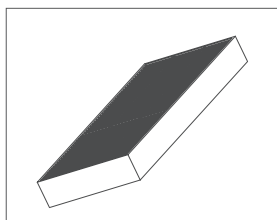

High Performance Filter

## Product parts

### Main product

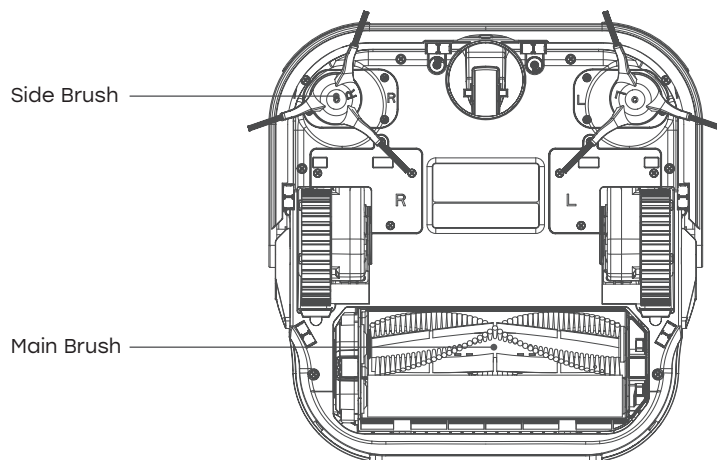
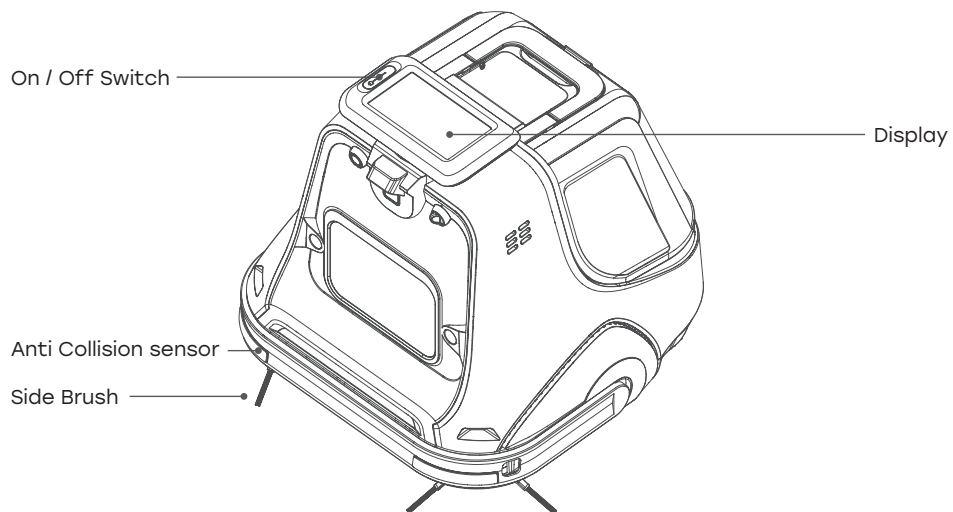

## Product parts

---

### Charging station

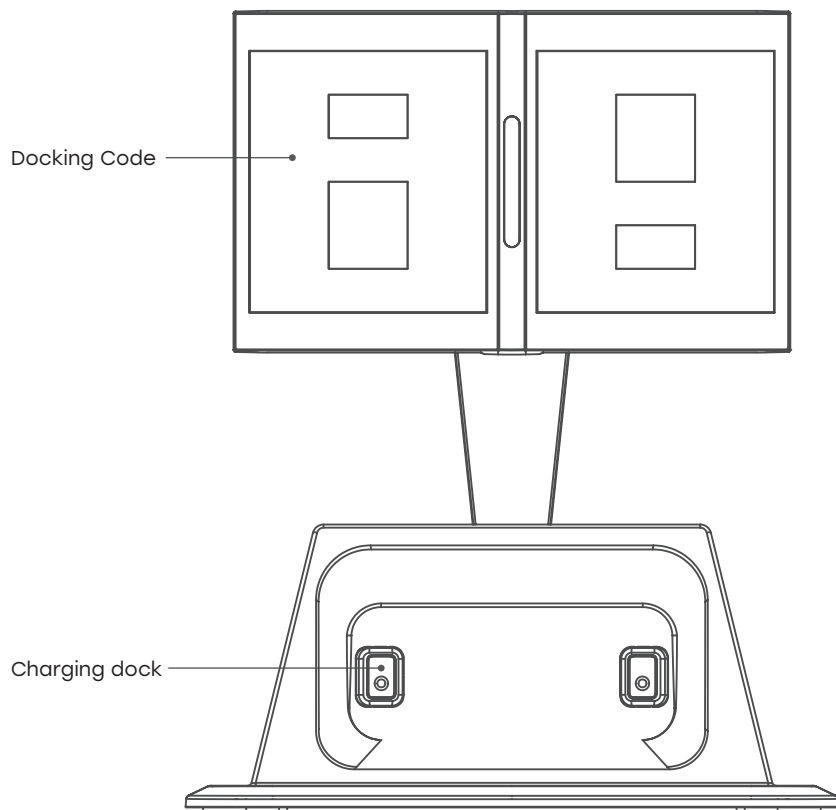

## Product parts

### Dust bin, Filter and Battery

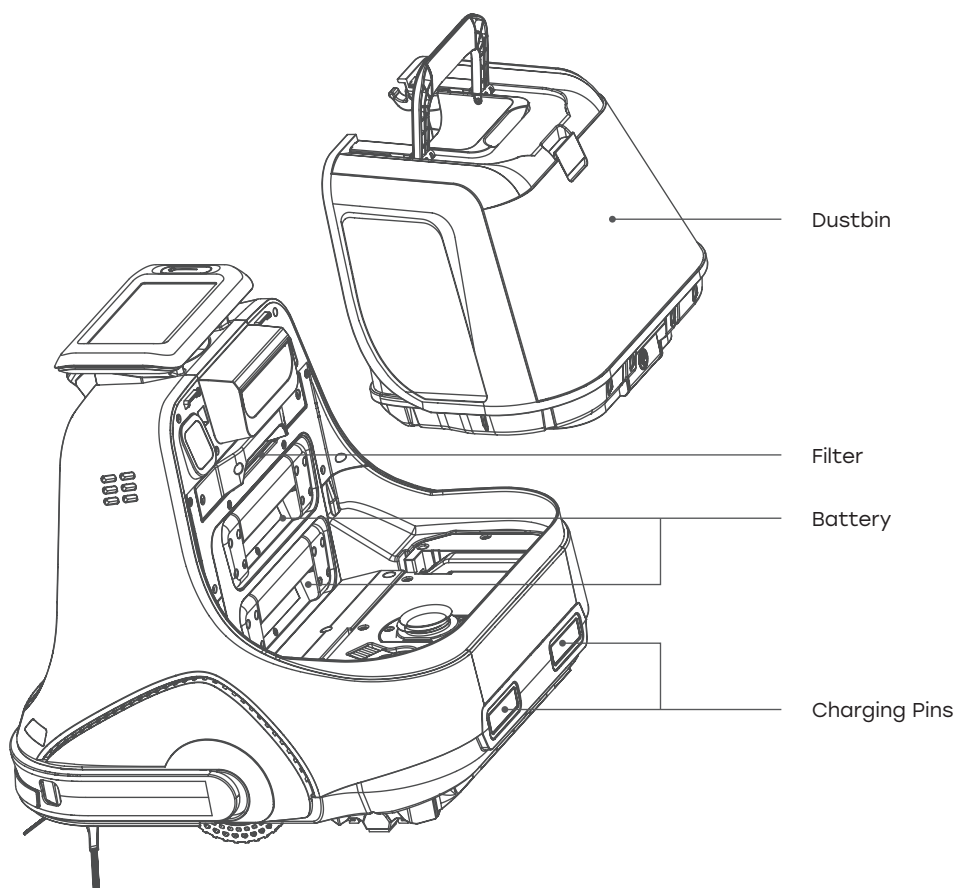

## Product operation

### Preparation Before Operating

1. Take the robot out of the box. Lift up the dustbin using the lever and remove the stickers and Packaging materials from the dust bin and the robot vacuum.
2. Put the dustbin back into place and lock it in with the lever.

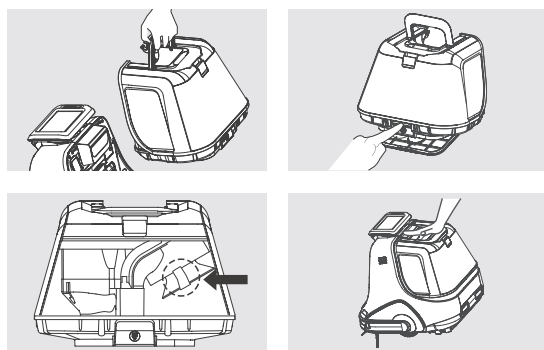

### Installing the Battery

Lift up the Dustbin, put the battery into the battery slot and press the battery in with both hands, until you hear a "click". When you hear the "click" sound, the battery is successfully installed.

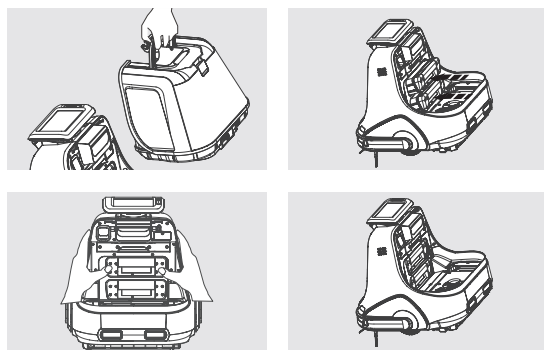

## Product operation

---

### Charging Station

1. Connect the adapter and charging station.
2. Place the charging station flat against the wall, the surrounding area is open and should not be covered by objects.
3. Connect the charging station to the power supply.
4. Press the power button to start up the Vacuum Cleaner.

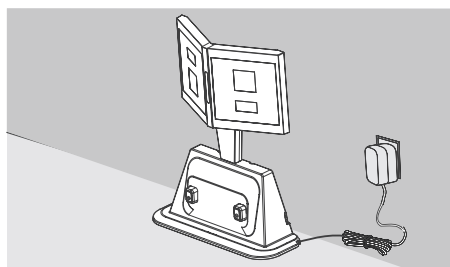
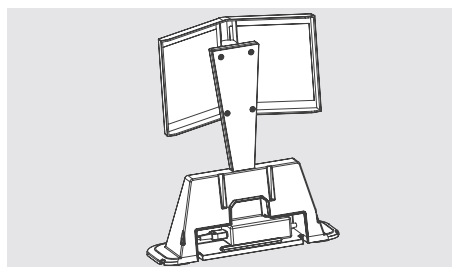

**NOTE** After cleaning is finished, it is recommended not to turn off the robot; keep the robot charging in the charging station so that it is ready to go the next time.

## Product operation

### Charging | Auto Charge

Press the recharge button  on the robot panel or App, the device will automatically search for the charging station to charge.

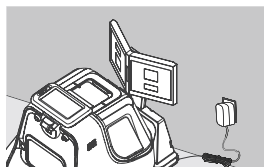

**NOTE** Pay attention to cleaning the charging dock of the charging station, otherwise the charging may not be possible.

**NOTE 1.** For daily use, please place the robot on the charging station, and ensure that the charging station is connected to the power supply and the robot power switch is on.

**2.** If the robot is not used for a longer time, please fully charge the machine, turn off the power, and store it in a dry and ventilated place.

### Start

1. Make sure the power is on.
2.  Press the button on robot & APP to start.

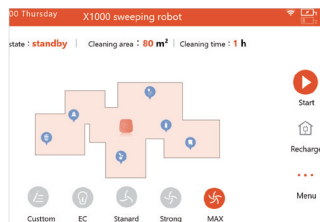

#### NOTE

 If the robot is in sleep mode, press again to wake up the robot to enter function selection mode, press the button again then the machine will start working automatically.

# Product operation

## Pause

- ① Press the button on robot or App to pause.

**NOTE** The machine can be re-operated after the machine has been paused.

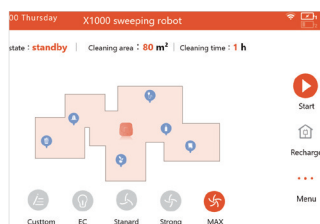

## Cleaning Mode Selection

### Energy Saving

- 💡 Press the energy saving button on the robot.

### Standard Mode

- 🌀 Press the standard button on the robot.

### Strong Mode

- 🌀 Press the power button on the robot.

### Max Mode

- 🌀 Press the MAX button on the robot.

### Customize

- ⚙️ Press the customize button to customize the side brush speed, roller brush speed & suction power.

## Product settings

---

### Select a map

To switch between created maps, select the map you want to use. Confirm your selection to use another map as the current map.

### Quick mapping

This function allows the X1000 to independently create a map to be used for cleaning.

### Virtual Wall / No-Go Area

To add a Virtual Wall or No-Go Area to the created maps, first select the map you want to edit from the „Select a Map“ menu. Select Virtual Wall or No-Go Area to draw it into the map.

Virtual walls can be used to prevent the robot from entering or leaving certain areas.

No-Go-Areas prevent the robot from reaching certain zones on the map.

Select and set up virtual wall or forbidden zone on the right-hand side of the menu.

### Select zone

Clean one or more rooms specifically. Select one or more rooms to have the X1000 clean in these rooms.

### Zoning

Select a specific area to clean on the map to send the X1000 to the area to clean.

### Schedule

Create schedules for the X1000 to clean at any time.

### Wireless LAN

Connect the X1000 to the app and your Wi-Fi network to conveniently control the X1000 from your smartphone. When the X1000 is connected to the Wi-Fi network, the firmware is automatically updated.

## Product settings

---

### Cleaning history

The last cleanings of the X1000 can be viewed here.

### System language

Select the desired system language.

### System time

Set the system time correctly.

### Volume setting

Set the volume of the X1000's voice prompts to the desired level.

### Power consumption setting

Can only be operated from the user interface in custom mode.

### Brush settings

Adjust the speed of the side brush, the main brush and the suction power.

### Carpet feature

Set the Carpet feature if the X1000 should increase its suction power on carpets and rugs.

### AI virtual wall

The X1000 recognises the included QR codes and does not leave the desired cleaning area.

### AI Recognition

With AI recognition, the X1000 recognises objects and records them in its cleaning history, so cables, boxes, shoes and other moving objects are detected and recorded as such in the map.

## Product settings

---

### **Automatic rotation**

The X1000 control panel rotates during cleaning to make it easier to operate when the X1000 is not in the charging station.

### **Automatic lock screen**

The X1000 control panel is locked during cleaning and in the charging station. It must be unlocked using the password, so only authorised persons can operate the X1000.

### **Password management**

Set a password to unlock the X1000 control panel.

### **Consumables statistics**

The consumables statistics show the condition of the X1000's wearing parts.

### **Factory data reset**

Reset the X1000 to its factory settings.

### **Version information**

Displays information about the firmware version of the X1000.

# App download and operation instruction

## App Download

Scan the QR code or search for "ZACOHme" to download, install and open the ZACOHme App.



## Connect the App

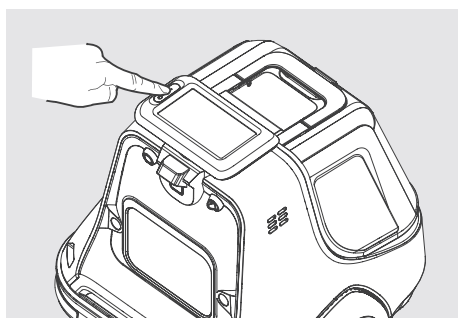

Turn on the Robot.

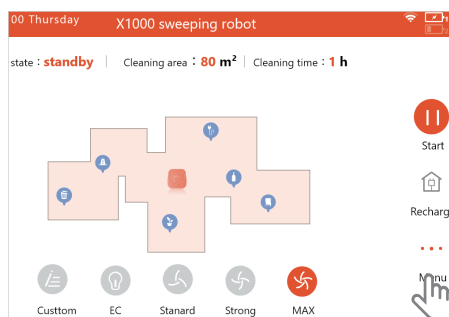

Click the menu button.

**NOTE** Connect your phone to an available WiFi network in the room.  
Make sure your phone is connected to an available WiFi network and has a good signal quality.

# App download and operation instruction

## Connect the App

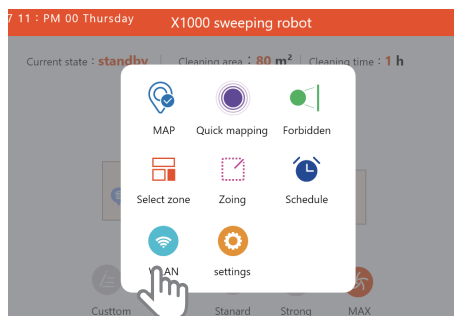

Click the Wi-Fi button on the Robot or select the Settings button and click Settings to enter the Wi-Fi password.

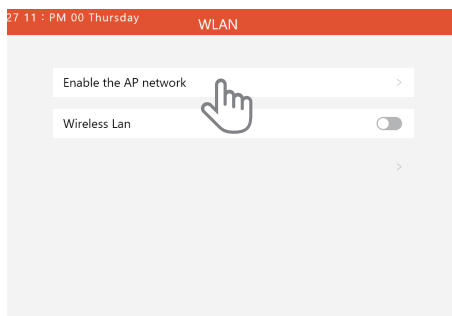

Select "Enable the App Network" to connect to AP network.

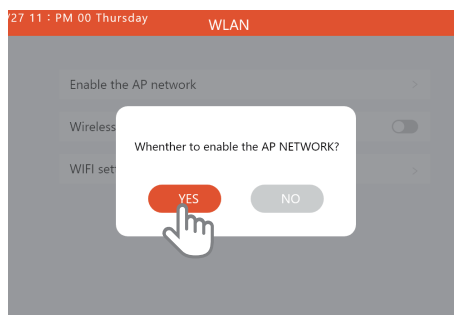

Click OK, the device will prompt "Wi-Fi connecting".

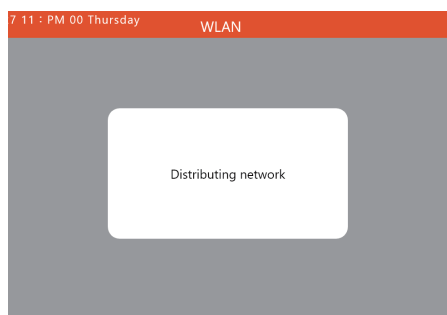

The robot prompts: the network is being configured.

# App download and operation instruction

## Connect the App

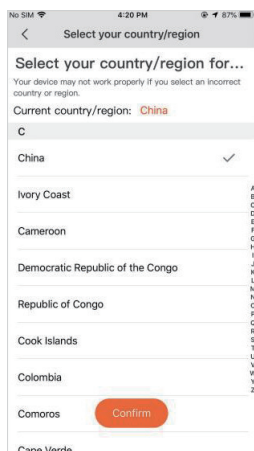

Select country or region.

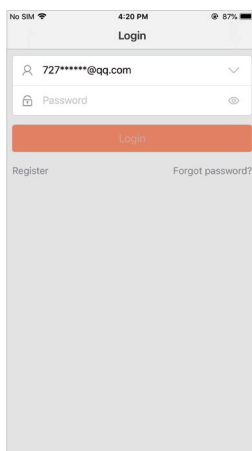

Register or sign in with your account.  
(Read and agree with User Registration Agreement).

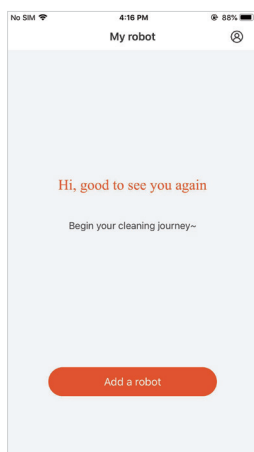

Select to add the robot.

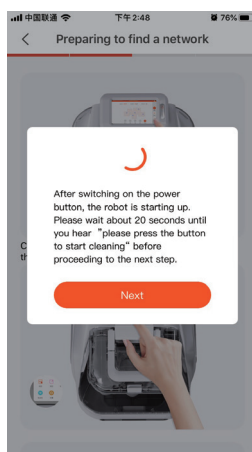

Confirm to continue.

# App download and operation instruction

## Connect the App

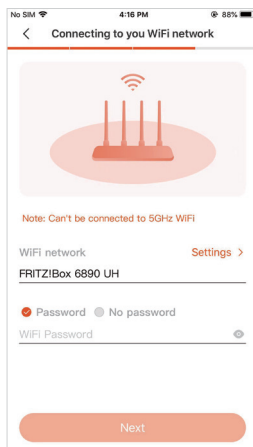

Fill in the WIFI password and continue.



Click on Settings to get to the phone settings, select the wireless network from host: adh-XXX

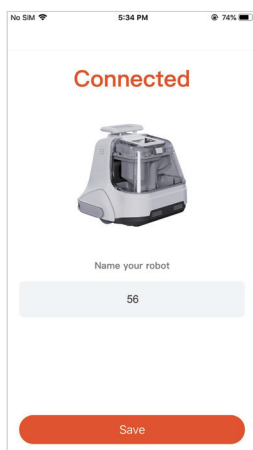

The connection is successful.

**NOTE** If the connection fails, please restart the device, and follow the steps to configure the network again.

# App download and operation instruction

## Disconnect the App

1. In the device list of App, click and hold the device you want to disconnect and swipe to the left. The disconnected button will appear on the right side of the device.
2. Click the disconnected button to disconnect the device.

## Control Robot

1. Click to select the device you want to control in the device list.

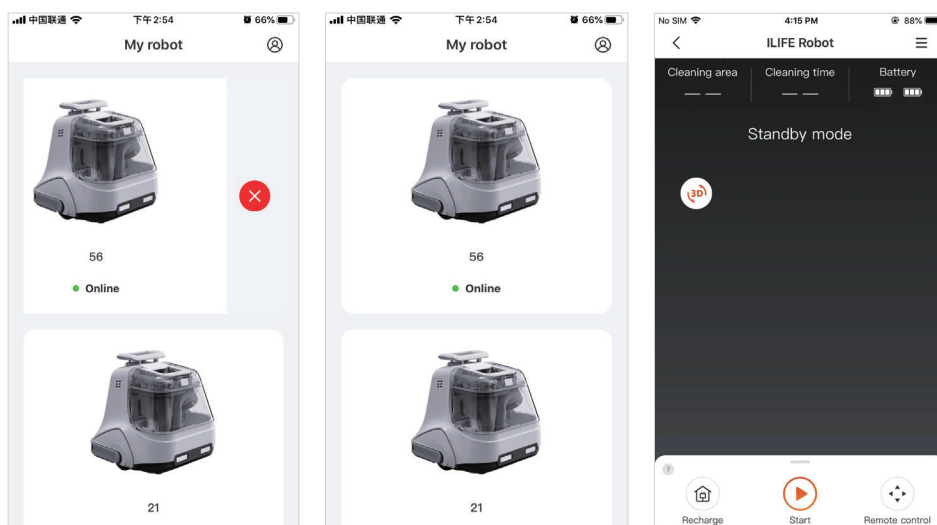

## Maintenance

### Side Brush Maintenance

1. Remove the side brush and clean the brush, remove any hair, or dust particles.

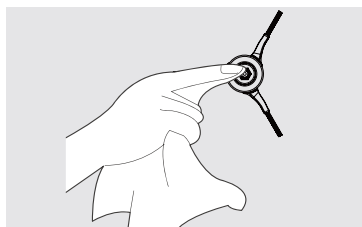

### Main Brush Maintenance

1. Remove the dustbin 2. Lift up the suction module by its lever. 3. Press the two buttons to release the brushes. 4. Take out the Brushes 5. Use the cleaning tool to remove the hair wrapped around the roller brush.

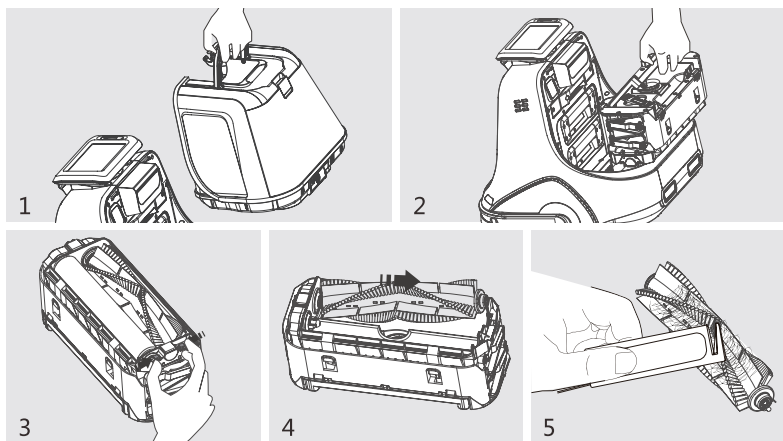

**NOTE** When cleaning and maintaining the device and accessories, please turn off the device and unplug the power supply of the charging station.

## Maintenance

### Front wheel Maintenance

1. Remove the front wheel and clean it to reduce the entanglement of hair and other particles.

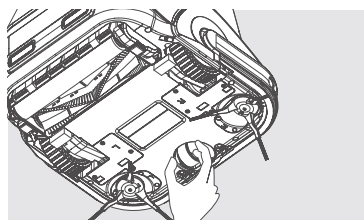

### Dust Bin and Filter Maintenance

1. Please clean the dustbin after each use.
2. Remove the dustbin. Press the button on the dustbin to release bottom cover of the dustbin automatically and empty the dustbin into a garbage can.
3. Remove the filter from the dustbin, wash the filter with clean water, and make sure it is completely dry when reinstalling the filter.

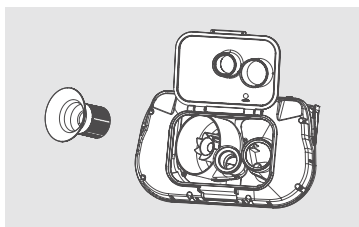
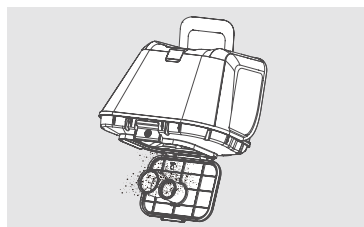
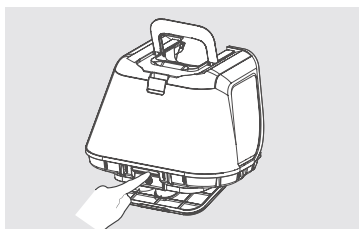
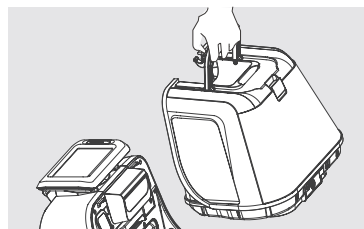

## Maintenance

### Filter Cleaning

1. Remove the HEPA 13 filter, wash with clean water, and place in a cool, ventilated place to dry, do not squeezing the high-performance filter.

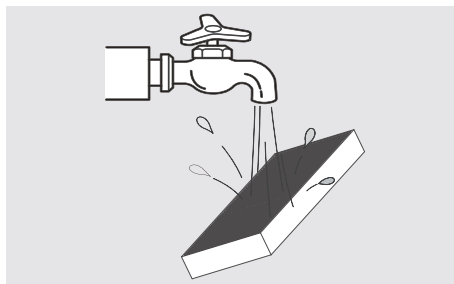
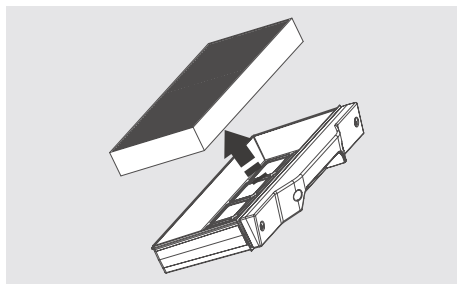
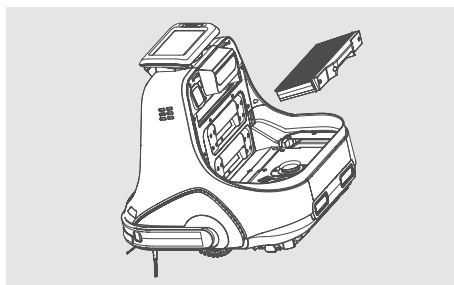
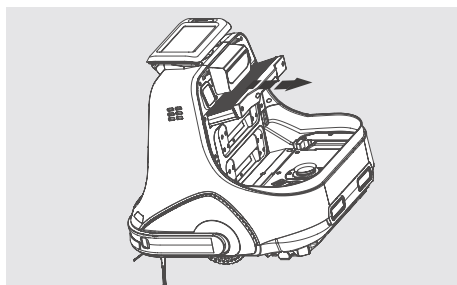

# Maintenance

## Cliff Sensors and Charging Pins Cleaning

1. Gently wipe the sensor and battery connector with a cleaning tool:

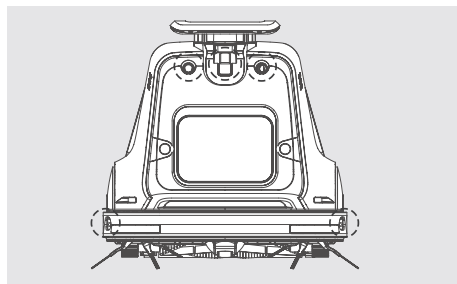
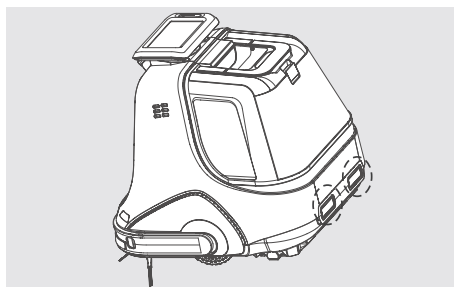
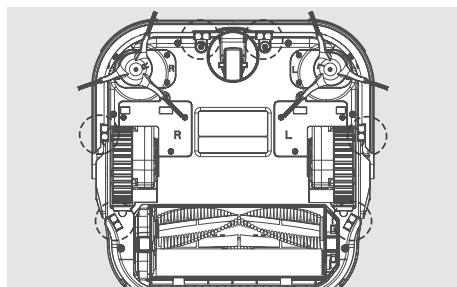

### NOTE

Clean the charging dock when there is dust on the cover.

When the device is not used for a long time, please take out the battery. And store it in a cool and dry place.

If the battery leaks, please remove the battery and exchange the battery. Dispose of the leaking battery as regulations require.

This device uses a long-life battery which does not need to be replaced frequently. If you need to replace it, please contact our after-sales service.

## Maintenance

---

### Maintenance And Replacing Accessories

Part	Cleaning	Replace
Dustbin	After each use	Only if defective
Filter	Once a week	Replace the new one every three to five months
Roller Brush	Once a week	Only if defective
Side Brush	Once a week	Only if defective
Charging Station	Once a week	Only if defective

## Product Specifications

---

Description	Specification
Nominal voltage	DC 25.2 V
Motor power	250 W
Charging voltage	32 V
Charging time	<300 min
Battery capacity	4700 mAh
Product size	376 x 372 x 365 mm
Maximum vacuum	20 kPa
Net weight	11.3 kg
Working times	210 min
Dust cup capacity	3 l

## PROTECTION CLASS

---

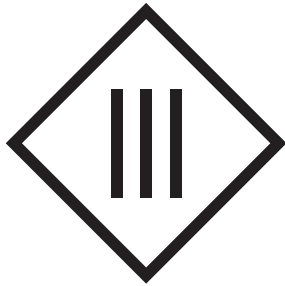

### **IEC Protection Class 3**

The device may only be used with the power supply provided. Only supply the device via a power supply unit that meets the requirements for safety extra-low voltage (SELV) in accordance with the marking on the device.

## ErP information

<b>Manufacturer information</b>	Dongguan Guanjin Electronics Technology Co., Ltd  Block 16 Qiantou New Industrial Park, Niushan, Dongcheng District, Dongguan City, Guangdong Province, China
<b>AC adapter Model identifier</b>	K65A320200E2
<b>Input voltage</b>	100-240V
<b>Input AC frequency</b>	50/60Hz
<b>Output voltage</b>	32.0Vdc
<b>Output current</b>	2.0A
<b>Output power</b>	64.0W
<b>Average active efficiency</b>	89.38 %
<b>Efficiency at low load (10 %)</b>	85.46 %
<b>No-load power consumption</b>	0.180 W

### Percentage of nameplate output current

<b>Load condition 1</b>	100%±2%
<b>Load condition 2</b>	75%±2%
<b>Load condition 3</b>	50%±2%
<b>Load condition 4</b>	25%±2%
<b>Load condition 5</b>	10%±1%

## Frequency Band

### Frequency Band and Output Power

<b>TX Frequency</b>	2.412 ~ 2.472 GHz 5.15-5.25 GHz (FCC UNII-low band) for US/Canada and Europe 5.25-5.35 GHz (FCC UNII-middle band) for US/Canada and Europe 5.47-5.725 GHz for Europe
<b>RX Frequency</b>	2.412 ~ 2.472 GHz 5.15-5.25 GHz (FCC UNII-low band) for US/Canada and Europe 5.25-5.35 GHz (FCC UNII-middle band) for US/Canada and Europe 5.47-5.725 GHz for Europe
<b>Antenna Gain</b>	≈3 dBi
<b>RF Output Power</b>	<b>2.4G</b> 802.11b:17 dB 802.11g:14 dB 802.11n:13 dB <b>5G</b> 802.11a:15 dB 802.11n:12 dB 802.11ac:11 dB

## EU Declaration of Conformity

**Robovox Distributions GmbH** hereby declares that the **X1000** radio complies with Directive 2014/53/EU.

The full text of the EU Declaration of Conformity can be found on the Internet address <https://conformity.zaco.eu/download/x1000.pdf>

The radio operates in the ISM band between 2.412 and 2.472 GHz.

The antenna gain is ≈3 dBi

# EU Declaration of Conformity

## Declaration of Conformity



**Product:** Electric vacuum cleaners (Robotic Vacuum Cleaner)  
**Model(s):** ZACO X1000  
**Supplied Accessories:** Refer to Annex 1  
**Manufacturer:** Robovox Distributions GmbH  
**Manufacturer address:** Hamburger Straße 11, 45889 Gelsenkirchen, Germany

<p>The manufacturer declares under full responsibility that above mentioned product is in conformity with the applicable requirements of the following directives:</p> <p><b>MD Directive:</b> 2006/42/EU  <b>RED Directive:</b> 2014/53/EU  <b>EMC Directive:</b> 2014/30/EU  <b>Low Voltage Directive:</b> 2014/35/EU  <b>RoHS Recast Directive:</b> 2011/65/EU  <b>WEEE Directive:</b> 2012/19/EU  <b>REACH Regulation:</b> 2006/1907/EC</p>	<p>Conformity with these directives has been assessed for this product by demonstrating compliance to the following harmonized standards and/or regulations:</p> <table border="1"> <tr> <td><b>SAFETY</b></td> <td>EN 60335-2-2:2010/A1: 2013 EN 60335-1:2012+A15:2021 EN 62233:2008</td> </tr> <tr> <td><b>EMC</b></td> <td>EN 301 489-1 V2.2.3:2019 EN 301 489-3 V2.2.3:2023 EN 301 489-17 V3.2.4:2020 EN IEC 55014-1:2021 EN IEC 55014-2:2021 EN IEC 61000-3-2:2019/A1:2021 EN IEC 61000-3-3:2013/A2:2021</td> </tr> <tr> <td><b>RF</b></td> <td>EN 300 328 V2.2.2 EN 301 893 V2.1.1 EN 300 440 V2.1.1 EN IEC 62311:2020 EN 50665:2017</td> </tr> <tr> <td><b>RoHS</b></td> <td>2011/65/EU</td> </tr> <tr> <td><b>WEEE</b></td> <td>2012/19/EU</td> </tr> <tr> <td><b>REACH</b></td> <td>2006/1907/EC</td> </tr> <tr> <td><b>MD</b></td> <td>EN 60335-2-69:2012 EN 60335-1:2012/A15:2021 EN 62233:2008 EN ISO 12100:2010</td> </tr> </table>	<b>SAFETY</b>	EN 60335-2-2:2010/A1: 2013 EN 60335-1:2012+A15:2021 EN 62233:2008	<b>EMC</b>	EN 301 489-1 V2.2.3:2019 EN 301 489-3 V2.2.3:2023 EN 301 489-17 V3.2.4:2020 EN IEC 55014-1:2021 EN IEC 55014-2:2021 EN IEC 61000-3-2:2019/A1:2021 EN IEC 61000-3-3:2013/A2:2021	<b>RF</b>	EN 300 328 V2.2.2 EN 301 893 V2.1.1 EN 300 440 V2.1.1 EN IEC 62311:2020 EN 50665:2017	<b>RoHS</b>	2011/65/EU	<b>WEEE</b>	2012/19/EU	<b>REACH</b>	2006/1907/EC	<b>MD</b>	EN 60335-2-69:2012 EN 60335-1:2012/A15:2021 EN 62233:2008 EN ISO 12100:2010
<b>SAFETY</b>	EN 60335-2-2:2010/A1: 2013 EN 60335-1:2012+A15:2021 EN 62233:2008														
<b>EMC</b>	EN 301 489-1 V2.2.3:2019 EN 301 489-3 V2.2.3:2023 EN 301 489-17 V3.2.4:2020 EN IEC 55014-1:2021 EN IEC 55014-2:2021 EN IEC 61000-3-2:2019/A1:2021 EN IEC 61000-3-3:2013/A2:2021														
<b>RF</b>	EN 300 328 V2.2.2 EN 301 893 V2.1.1 EN 300 440 V2.1.1 EN IEC 62311:2020 EN 50665:2017														
<b>RoHS</b>	2011/65/EU														
<b>WEEE</b>	2012/19/EU														
<b>REACH</b>	2006/1907/EC														
<b>MD</b>	EN 60335-2-69:2012 EN 60335-1:2012/A15:2021 EN 62233:2008 EN ISO 12100:2010														

Gelsenkirchen, Date, 2023 / 08 / 01

  
 (Oliver Böhler, authorized Proxy)



Robovox Distributions GmbH - Hamburger Str. 11 - 45889 Gelsenkirchen - Germany

### Annex 1

Item	Model Number	Quantity	Software*	Remark
Robotic Vacuum Cleaner	X1000	1	0072	Essential
Battery Set	U106-H18650CH-72SP	1	/	Essential
Chargin Dock		1	/	Accessory
Main Brush Set		1	/	Accessory
Side Brush Set		1	/	Accessory
High Performance Filter		1	/	Accessory

\*Note: All updated versions released by the manufacturer have been verified to be complied with the applicable regulations, All RG parameters (e.g., RF power, frequency) are not accessible to end users and cannot be changed by any third party.